

BEFORE THE ADDITIONAL FACILITY OF THE
INTERNATIONAL CENTRE FOR SETTLEMENT OF
INVESTMENT DISPUTE (ICSID)

BETWEEN:

MERCER INTERNATIONAL INC.

Claimant

AND:

GOVERNMENT OF CANADA

Respondent

ICSID CASE NO. ARB(AF)/12/3

SECOND WITNESS STATEMENT OF LESTER DYCK

9 April 2015

I, Lester Dyck, declare as follows:

1. I present this second witness statement to respond to facts alleged in the Claimant’s Reply of 16 December 2014 and its accompanying witness statements and expert reports.

2. I have organized my testimony in the following manner: First, I will reiterate the purpose and principles underlying BC Hydro’s use of generator baselines (“GBLs”) in Electricity Purchase Agreements (“EPAs”). Next, I will provide further details and respond to specific factual allegations raised in relation to the GBLs in each of the EPAs between BC Hydro and Celgar, Tembec, and Howe Sound. Finally, I will discuss the annual renewals of Howe Sound’s 2001 Consent Agreement.

A. BC HYDRO’S USE OF GENERATOR BASELINES IN EPAS

3. GBLs are used in EPAs and Load Displacement Agreements (“LDAs”)¹ between BC Hydro and self-generators to identify the amount of energy the self-generator would make in the absence of the incentive contract (*i.e.* “normal” generation) so that BC Hydro pays the contract price only for that energy the self-generator would not otherwise generate in the absence of the incentive (*i.e.* for “incremental” generation). BC Hydro does not pay for “normal” generation.

4. BC Hydro assesses what constitutes a self-generator’s “normal” generation, which it will not incentivize through an EPA or LDA, versus “incremental” generation that it might choose to incentivize, at a particular point in time. Specifically, it is necessary to assess “normal” generation during a procurement process to award a contract or contracts that incentivize “incremental” self-generation.

5. Like any other industrial process, a pulp mill’s operations will change over time, and from time to time. For example, a mill operator might reconfigure mill equipment or invest in new equipment to increase mill production and/or efficiency. Operations might

¹ In my first witness statement, at ¶¶ 28-30 I explained some of the differences between the LDA and EPA contract structures for incentivizing incremental self-generation. In this second witness statement, I focus on EPAs.

also change as mill equipment degrades. As BC Hydro's objective is for the counterparty to self-generate more energy than it normally would (*i.e.* in the absence of a contract incentive), the focus is always on normal operating conditions at the time of negotiating the incentive contract. For the purposes of its EPAs, BC Hydro reviews the most recent historical data with a self-generating counterparty in order to agree on what normal operations are for the counterparty at that time.

6. BC Hydro's use of GBLs in its EPAs with self-generators is not about complying with BCUC Order G-38-01. BC Hydro's use of GBLs in its EPAs with self-generators shares the underlying principle of Order G-38-01 that a utility should not allow its self-generating customer to arbitrage between embedded cost of service rates and market prices (or the incentive contract price, in the case of EPAs) to the detriment of ratepayers in the form of higher rates. However, whereas the GBLs in EPAs are used in connection with providing an incentive for self-generating customers to generate more energy than they otherwise would in the context of BC Hydro's procurement of energy, Order G-38-01 contemplates the use of a baseline in connection with limiting a utility's obligation to serve a self-generating customer who is selling electricity to a third party.² That situation is not tied to procurement by BC Hydro at all. BC Hydro's use of a GBL in an EPA with a self-generator is not connected to its obligations to serve its customers.

² In my first statement, I stated the following at ¶ 37: "...The BCUC staff report appended to Order G-38-01 describes 'incremental' self-generation as the electricity generated by the customer above what it generates for self-supply under current normal operating conditions." The Claimant says that the BCUC Staff Report appended to Order G-38-01 does not mention current normal operating conditions: *see* Claimant's Reply, ¶ 251. In my first statement, I was referring to the BCUC Staff Report appended to Order G-38-01 at page 1 where it says "B.C. Hydro made a further submission on February 28, 2001 in which it accepted HSP's general proposition: that supply-constrained energy markets may benefit from initiatives aimed at encouraging idle capacity to come back on line. B.C. Hydro also accepted that the sale of truly 'idle' generation into the market may not harm other ratepayers, as long as increased takes of RS 1821 electricity were not above normal historical levels, to produce the current 'idle' capacity." Commission Staff Report, Appendix A to G-38-01, **R-19**. As I set out in my first witness statement, BC Hydro subsequently developed a definition for incremental generation - that which is in excess of the mill's normal operations at the time of negotiations - in the context of its power procurement processes, the only times following G-38-01 that the issue arose: *see* Lester Dyck Statement I, ¶¶ 42-50.

B. THE GBL IN CELGAR'S 2009 EPA

1. The Claimant Understood the Purpose and Principles Underlying GBLs in BC Hydro's EPAs

7. Mr. Merwin complains in his second witness statement that the explanation of the GBL provided to proponents of Bio Phase I, such as Celgar, in BC Hydro's Request for Expressions of Interest (April 2007),³ Request for Proposals (issued on February 6, 2008),⁴ information presentations (specifically the one at Kamloops on 20 February 2008),⁵ and Registration Forms (particularly the Preliminary GBL Data form issued as part of Addendum 1 on February 26, 2008),⁶ prior to the bid submission deadline of June 10, 2008, contained no mention of the exclusivity clause of the EPA.⁷ The exclusivity clause is a term of the form EPA used for Bio Phase I and is not related to the GBL determination. Indeed, the GBL and the discussions to set it were a separate, earlier phase of the procurement process. I had no involvement in the negotiations of the terms of the EPA, which came later -- that responsibility fell to the Power Acquisitions group. I understand that Mr. Scouras explains in his second witness statement that an exclusivity clause was included in the Specimen EPA and RFP Addendum of May 7, 2008.⁸

8. The role of the annual GBL that I was involved with determining was to identify what energy was eligible for sale into the procurement process, meaning the new or incremental energy that was in excess of the energy the proponent generated under current normal operating conditions.⁹ As I previously testified, this concept was presented to potential proponents of Bio Phase I on numerous occasions.¹⁰ The Claimant

³ Celgar, 2007 Bioenergy RFEOI Form, April 2007, ("2007 Bioenergy RFEOI Form"), **R-111**.

⁴ Bioenergy Phase I – RFP, pp. 6-7, **R-25**.

⁵ BC Hydro's Bioenergy Call, Kamloops, BC, February 20, 2008 Presentation, p. 22, **R-116**.

⁶ BC Hydro Bioenergy Call for Power – Phase I, Addendum 1, 26 February 2008, **R-113**.

⁷ Merwin Witness Statement II, ¶¶ 7-8.

⁸ Jim Scouras Statement II, ¶ 7.

⁹ See Lester Dyck Statement I, ¶ 88 ("I considered the same factors and applied the same principles when setting the GBL for every proponent in Bio Phase I and in subsequent calls, including Celgar. I examined historical generation data and evaluated what any given mill generates under current normal operating conditions, as well as the impact of existing commitments for their generation.")

¹⁰ Lester Dyck Statement I, ¶¶ 56-59.

complains that the “PowerPoint presentation slide deck used by BC Hydro in February 2008 contains a single slide on GBLs.”¹¹ The Claimant’s comment ignores that there was an additional information session held shortly thereafter on March 26, 2008, which included a GBL break-out session.¹² At this break-out session, BC Hydro discussed the purpose and method of setting a GBL in an EPA for customer projects and answered proponent questions, including a question on whether a GBL is needed from a proponent who is not a BC Hydro customer.¹³ Following these information sessions, BC Hydro met with proponents one-on-one to discuss their projects and answer any further questions they may have had about the process. As I mentioned in my first statement, Celgar had one-on-one meetings with BC Hydro both late in March 2008, and on April 2, 2008.¹⁴

9. Mr. Merwin also asserts that he understood that the data he submitted for the purpose of determining the Celgar mill’s GBL were “nothing more than a suggested starting point for potential negotiations.”¹⁵ He is right about this point. In fact, we had several meetings and conversations after he submitted additional operational data on May 7, 2008,¹⁶ and until the annual GBL figure was set for the EPA on May 30, 2008.¹⁷ I described these conversations in my first witness statement,¹⁸ and discuss further the content of some of our conversations below. I also note that, in both of the other cases the Claimant raises in this proceeding, the mill in question proposed a GBL as a starting point that was not the GBL figure ultimately agreed to in the EPA.¹⁹

¹¹ Claimant’s Reply, ¶ 255.

¹² Phase I Bioenergy Call Proponent Workshop – Agenda, 26 March 2008, **R-527**.

¹³ The answer was yes. See Email from David Keir to Lester Dyck re: Summary of GBL Discussion – 26 March 2008, dated March 27, 2008 at 064463, **R-173**.

¹⁴ Lester Dyck Statement I, ¶ 69.

¹⁵ Merwin Witness Statement II, ¶ 9.

¹⁶ Letter from Brian Merwin to BC Hydro RFP Administrator, re: Zellstoff Celgar Limited Partnership (“Celgar”) - Biomass Realization Project and Celgar Green Energy Project, dated May 7, 2008, **R-127**.

¹⁷ Letter from RFP Administrator (Bioenergy Call - Phase I) to Brian Merwin Re: Bioenergy Call (Phase I) - GBL dated May 30, 2008, **R-181**.

¹⁸ Lester Dyck Statement I, ¶¶ 81-82.

¹⁹ Tembec proposed a GBL of [REDACTED]; the EPA GBL was 14 MW. Howe Sound proposed a GBL of around [REDACTED] (on the basis of [REDACTED] >generation data); the EPA GBL was [REDACTED]

10. Mr. Merwin alleges that BC Hydro “never articulated (either in writing or orally) [a ‘current normal operating conditions’] standard to Celgar at any point during the entire course of the Bio Phase I process and EPA negotiations.”²⁰ However, Mr. Merwin understood that the purpose and principle of GBLs in the context of BC Hydro’s Bio Phase I process is to identify the mill’s “normal” generation that BC Hydro will not incentivize in the EPA.

11. For example, once BC Hydro informed Celgar that its Biomass Realization Project was not eligible for sale in Bio Phase I, Mr. Merwin insisted that a fixed GBL be set for the Celgar mill in the following manner:

As the Celgar Green Energy project will include “BC Hydro determined eligible energy” from both the new and existing generators we will need to work with BC Hydro to establish the equivalent of a GBL similar to that which has been established with BC Hydro’s customers under the RFP process. We have attached existing data and are recommending a GBL equivalent of 33 MW (Attachment 1).²¹

12. The logic of Mr. Merwin’s GBL proposal of 33 MW reflects his understanding that a GBL should represent what a mill would normally generate without an incentive contract. It appears that this proposal from Celgar was based on the total gross generation of the mill in 2006, adjusted for excess natural gas used to generate electricity in excess of the mill’s needs (as shown in the “Generator Baseline” table in Mr. Merwin’s May 7, 2008 letter) and that his proposed GBL of 33 MW reflects his position of “normal” operations for the mill during that time frame.²²

13. Mr. Merwin also claims that “the information that BC Hydro did provide concerning its GBL determination standards gave the impression that BC Hydro would consider a number of years – what seemed like an average of three years of operational

²⁰ Merwin Witness Statement II, ¶ 15.

²¹ Letter from Brian Merwin to BC Hydro RFP Administrator, re: Zellstoff Celgar Limited Partnership (“Celgar”) - Biomass Realization Project and Celgar Green Energy Project, dated May 7, 2008, pp. 2 and 5, **R-127**.

²² See Letter from Brian Merwin to BC Hydro RFP Administrator, re: Zellstoff Celgar Limited Partnership (“Celgar”) - Biomass Realization Project and Celgar Green Energy Project, dated May 7, 2008, p. 5, **R-127**.

data – not simply one year of data or only ‘current’ data.”²³ He explains that he was “particularly shocked and disturbed when Mr. Dyck informed me that BC Hydro had only considered one year (2007, the year prior to our BioEnergy Phase I registration) of operational data in assigning Celgar’s GBL.”²⁴ These allegations are inaccurate and misleading for two reasons.

14. First, Mr. Merwin’s 33 MW proposal of May 7, 2008 based on Celgar’s adjusted generation in 2006,²⁵ as well as his initial GBL Registration Form proposal of 34.3 MW (300.2 GWh/year) based on Celgar’s gross generation level in 2005,²⁶ were both based on one calendar year’s generation and not an average of several years of data. If, as he now says, BC Hydro gave him the impression that it would use an average of three years’ data to set GBLs for proponents, I expect that Mr. Merwin would have proposed a GBL on that basis at the time.

15. Second, Mr. Merwin confuses the time range of data that BC Hydro reviewed, and the determination of the GBL. In every case where BC Hydro set a GBL, we started with a range of operational data – typically three to five years prior to the start of the negotiation of the EPA for which the GBL was being set – in order to determine through discussions with the proponent whether a recent one-year historical period represented normal operations at that time, or alternatively, which recent one-year period best represented normal operations at that time. For example, in the case of [REDACTED]

[REDACTED]

[REDACTED]

[REDACTED]

²³ Merwin Witness Statement II, ¶ 15.

²⁴ Merwin Witness Statement II, ¶ 16

²⁵ BC Hydro Bioenergy Call for Power (Phase I) – Registration Forms, 6 March 2008 at MER00278907, **R-123**.

²⁶ See Lester Dyck Statement I, ¶¶ 78-79; Letter from Brian Merwin to BC Hydro RFP Administrator, re: Zellstoff Celgar Limited Partnership (“Celgar”) – Biomass Realization Project and Celgar Green Energy Project, dated May 7, 2008 at 019775, **R-127**.

16. The exercise was no different for Celgar. Rather than considering “only one year” as Mr. Merwin contends, I reviewed the broader range of data submitted by Celgar -- from 2002 until 2007, in addition to statements Mr. Merwin made about the mill’s projections for future performance.²⁷ I considered and decided to disregard Celgar’s data from 2002 to 2004. Considering data prior to Mercer’s acquisition of the mill out of bankruptcy in 2005 would not have been appropriate because that data did not reflect the operational decisions of the current owner; nor did it reflect the subsequent equipment changes that were made to the mill by Celgar after 2005.

17. As I testified previously, Celgar had increased its pulp production and steam efficiencies in 2005 and 2006.²⁸ The data from those two years reflected the impact of the significant changes that the mill was implementing at that time. Among the data presented to and considered by BC Hydro, 2007 was the Celgar mill’s first full operating year after the significant operational changes implemented through Project Blue Goose.²⁹ In follow-up conversations, Mr. Merwin confirmed that 2007 represented normal operations for Celgar going forward.³⁰

2. Normal Operations at the Celgar Mill

18. The Claimant has three primary complaints about the way its GBL was set. The first is that BC Hydro should have subtracted Celgar’s 2007 sales from its gross generation in order to set its GBL. The second is that BC Hydro should have used a different year or combination of years to set Celgar’s GBL. The third is that BC Hydro should have considered Celgar’s “financial and economic circumstances” to set Celgar’s GBL. I will address each of these points in turn.

²⁷ Lester Dyck Statement I, ¶ 78-83.

²⁸ Lester Dyck Statement I, ¶¶ 80-81.

²⁹ Lester Dyck Statement I, ¶ 86.

³⁰ Lester Dyck Statement I, ¶ 86. *See also* Letter from Brian Merwin to BC Hydro RFP Administrator, re: Zellstoff Celgar Limited Partnership (“Celgar”) - Biomass Realization Project and Celgar Green Energy Project, dated May 7, 2008, **R-127** p. 7 (showing “Celgar Operation 2007” diagram that “represents how Celgar typically operates after Mercer capital investments.” This diagram shows a 2007 “March” mill load of 43 MW, generation levels for the same of 48 MW, and exports of 5 MW.)

19. As I described in my first witness statement, I had several conversations and in-person meetings with Mr. Merwin following his May 7, 2008 letter to confirm what normal operations looked like for the mill.³¹ In these conversations, I asked Mr. Merwin under what circumstances the mill made electricity sales. He responded that the mill sold energy when it generated in excess of its load. I understood Mr. Merwin's response to mean that the mill sold the energy that it actually injected into the FortisBC system from time to time. When I asked him why this was, his answer was "because there was an opportunity, and they could." I asked him when the mill purchased electricity from its utility, FortisBC. Mr. Merwin replied that they purchased only during generator downtimes, whether planned or unplanned. To clarify what I was trying to determine, I asked Mr. Merwin specifically whether, in normal circumstances, the mill was completely self-sufficient. His answer was yes.

20. Mr. Merwin now claims that he did not understand specifically what I meant by "normal operations" in our discussions:

I note that Lester Dyck testifies that, in our discussions regarding the calculation of Celgar's GBL, "Mr. Merwin confirmed that 2007 represented normal operations for Celgar going forward." I would only clarify that Mr. Dyck never explained that by "normal" he meant that Celgar would "normally" choose to operate the mill that level (i.e., Celgar would generate excess steam to generate surplus electricity) regardless of whether Celgar had contractual arrangements to sell the excess electricity it generated. When Mr. Dyck asked me that question, I had no idea that he would disregard our electricity sales contracts. I had no understanding of the context of his question, as BC Hydro failed to disclose to me what it now describe as its "current normal operating conditions" GBL standard.³²

21. In all of my conversations with Mr. Merwin - and there were many of them during the GBL setting process - he never once raised any concerns about the meaning of "normal operations." Based on the information he was providing to me, in the form of his project presentation on April 2, 2008, his May 7, 2008 letter, and the answers to

³¹ See Lester Dyck Statement I, ¶¶ 81-82.

³² Merwin Witness Statement II, ¶ 18.

questions I had, it was clear to me that Mr. Merwin understood what I meant. The way he described how the Celgar mill operated, and when it sold and purchased electricity, never raised a doubt in my mind that he knew that I was interested in understanding under what conditions Celgar normally bought and sold electricity.

22. Mr. Merwin's letter of May 7, 2008 to BC Hydro shows that he understood what "normal operating conditions" meant for the Celgar mill, and that he was representing that the mill was normally meeting its entire load:

Historically, under normal operating conditions Celgar's load was 38 MW to 39 MW. In 2007, Celgar's load under normal operating conditions was 43 MW, depending on whether Celgar's chipping plant is running this number could go as high as 45 MW. During less than ideal operating conditions the mill load would likely be a slightly lower number. As Celgar moves to a higher reliability, meaning running at target rates, there will be a higher frequency when Celgar's load is equal or greater than 43 MW.³³

23. Mr. Merwin included in his May 7, 2008 letter a single line diagram of the mill's "typical" operations after Mercer's capital investments completed in 2005 and 2006.³⁴ This diagram showed electricity generation of 48 MW and, of that amount, 5 MW is exported, which means that 43 MW is consumed by the mill load as shown in the diagrams for both winter and summer. The letter also shows (on page 5) that the Celgar mill operates for 8400 hours/year out of the 8760 hours in 365 days. It then stands to reason that if the mill's self-generation is normally equal to the mill load at 43 MW/hour and the mill normally operates for 8400 hours/year, the annual load and self-generation are expected to be 361.2 GWh/year (8400 hours * 43 MW/hour). Based on the "Historic Data" table on page 4 of the same letter, the actual mill consumption in 2007 was slightly more than 349 GWh. This confirms that the annual GBL for the mill of 349 GWh/year was a relatively low estimate of what the mill would generate with its existing assets on a

³³ Letter from Brian Merwin to BC Hydro RFP Administrator, re: Zellstoff Celgar Limited Partnership ("Celgar") - Biomass Realization Project and Celgar Green Energy Project, dated May 7, 2008, p. 4, **R-127**.

³⁴ Letter from Brian Merwin to BC Hydro RFP Administrator, re: Zellstoff Celgar Limited Partnership ("Celgar") - Biomass Realization Project and Celgar Green Energy Project, dated May 7, 2008, p. 7, **R-127**.

going-forward basis. It also confirms that the GBL was appropriately set equal to the mill load based on the best available information at the time.

24. The Claimant now suggests in its Reply that Celgar's GBL in the 2009 EPA should have been 326.7 GWh/year - which represents the Celgar mill's total generation in 2007 less its gross energy sales that year, or its load less its purchases from FortisBC.³⁵ According to the Claimant, this would represent the amount of self-generation the mill used for self-supply.³⁶ Mr. Merwin, for his part, represents now that, without the NorthPoint and FortisBC sales contracts, the mill would have produced only enough steam to meet the mill's thermal needs.³⁷

25. Neither of these scenarios is consistent with Mr. Merwin's representations during our discussions in April and May 2008 that the mill was electrically self-sufficient under normal operating conditions. Mr. Merwin did not convey that the mill would decrease steam production without the sales contracts. Quite the opposite - Mr. Merwin described that, as a result of the Blue Goose improvements, the mill would be producing even more steam than it had in the past, using primarily black liquor in its recovery boiler, which was a by-product of increased pulp production. The electricity generated by this steam was sufficient to meet the mill's load under normal operating conditions, and sometimes exceeded the mill's needs. I understood that it was under these circumstances that the mill sold electricity to FortisBC or to NorthPoint.³⁸

26. As I described previously, the Blue Goose project was primarily focused on increasing pulp production and enhancing the reliability and efficiency of the pulp mill's

³⁵ Claimant's Reply, ¶ 376.

³⁶ Claimant's Reply, ¶ 375.

³⁷ Merwin Witness Statement II, ¶¶ 27-29.

³⁸ The electricity Celgar sold to FortisBC and NorthPoint was at all times net of mill load. This is in contrast to the [REDACTED] Moreover, [REDACTED]

Pierre Lamarche Statement II, ¶ 7.

[REDACTED] This is in contrast to Celgar's case, where Celgar confirmed that the mill is fully self-sufficient under normal operating conditions (i.e., in the absence of any market sales opportunities).

operations.³⁹ The 2007 generation figures reflected these improvements, and Mr. Merwin was clear that steam production (along with electricity generation) at the mill was expected to increase even more in 2008 (which it did).

27. Under these circumstances, to set the GBL at 326.7 GWh/year would have been contrary to the best available information. We would have had to assume that the mill's generation output would be approximately 22 GWh/year below the mill load of 349 GWh/year under normal operating conditions. Based on my understanding of the mill's operations, as communicated to me by Mr. Merwin at the relevant time, the only way that the mill could generate 327 GWh/year when operating normally is if the mill was intentionally under-utilizing its generation capacity by venting steam and wasting thermal energy.

28. Mr. Merwin describes again that he did not understand what "normal" meant in the context of our discussions about Celgar's GBL and that, had he understood differently, he would also "have told [me] that [they] did not have sufficient information on whether [their] 2007 operations were normal. [They] had just installed new equipment and made process improvements as a result of Project Blue Goose, and [they] did not yet have sufficient experience to determine the reliability of the new plant configuration, nor had [they] had sufficient time to evaluate whether problems might arise."⁴⁰

29. Mr. Merwin again never mentioned that Celgar might have questions about the reliability of Blue Goose. To the contrary, he boasted about the efficiency improvements, and communicated to us that the mill's load would grow, and its generation would grow to match it.⁴¹ In this context of an upward pattern of generation – which was ultimately reflected in the mill's operations⁴² – setting the GBL at the mill's 2007 load was actually a low, and favourable to Celgar, estimate of how much the mill would be expected to generate on a going-forward basis in the absence of an EPA with BC Hydro.

³⁹ Lester Dyck Statement I, ¶ 86.

⁴⁰ Merwin Witness Statement II, ¶ 19.

⁴¹ Lester Dyck Statement I, ¶ 83.

⁴² See Merwin Witness Statement II, Annex A.

30. In his second witness statement, Mr. Merwin also takes issue with what he describes as BC Hydro's failure to consider "whether Celgar's electricity generation was 'normal' in terms of Celgar's "economic or financial circumstances", and BC Hydro never communicated in writing or orally that economic or financial data regarding the Mill's operations would have been relevant to its calculation of Celgar's GBL."⁴³ The recent historical generation data of the mill already reflects that mill's weighing of economic and financial factors in operating decisions and, as discussed above and in my first witness statement, Celgar represented to BC Hydro several times that the mill's operations in 2007 represented normal operations going forward. This approach was the same for every mill -- the focus of setting the annual GBL was the level of self-generation output that reflects the operating decisions the mill normally makes, using the best information at the time of negotiating the EPA.

C. THE GBL IN TEMBEC SKOOKUMCHUCK'S 2009 EPA

1. Early Termination and Skookumchuck's Operations in the Absence of the 1997 EPA

31. Tembec and BC Hydro began exploring the possibility of renegotiating the 1997 EPA in December 2008, [REDACTED]

[REDACTED] I understand that Mr. Christian Lague, the Energy Coordinator at the Skookumchuck mill at that time, describes in greater detail the reasons for [REDACTED] [REDACTED] and the manner in which the mill was operating under the 1997 EPA in his witness statement.⁴⁴

32. In my first witness statement, I explained the conditions that existed at the time we were negotiating the 2009 EPA with Tembec:

106. Tembec was the only case where I had to determine a GBL where the customer's historical plant and generation operation data reflected (1) the influence of a major pre-existing contract that was now coming to an end, and (2) [REDACTED]

⁴³ Merwin Witness Statement II, ¶ 17.

⁴⁴ Christian Lague Statement, ¶¶ 26-41.

[REDACTED]
The obligations in the existing contract were about to disappear,
[REDACTED]

107. For the purposes of setting a GBL under these circumstances, the parties determined that, in normal operations, [REDACTED]
[REDACTED]

33. In addition, as I stated in paragraph 110 of my first witness statement, [REDACTED]
[REDACTED]
[REDACTED] produced a GBL figure of 14 MW/hr (122.6 GWh/year) for the 2009 EPA.

34. Mr. Switlishoff points to Tembec's generation data from the period of May to August 2009 - [REDACTED]

[REDACTED]
[REDACTED]
[REDACTED]
[REDACTED]
[REDACTED]
[REDACTED],⁴⁵

35. Mr. Switlishoff's comment misses the point. The Skookumchuck mill's operations during May to August 2009, [REDACTED]

[REDACTED]
[REDACTED]⁴⁶ As I explained in my first witness statement, the expected generation at the Skookumchuck mill in the absence of the 1997 EPA (or any

⁴⁵ Switlishoff Expert Statement II, ¶¶ 75-76.

⁴⁶ I understand from reviewing the 2001 ESA that BC Hydro and Tembec agreed in the implementation of the 1997 EPA and 2001 ESA that Tembec would [REDACTED]
[REDACTED]: Appendix to Electricity Supply Agreement between British Columbia Hydro and Power Authority and Tembec Industries Inc. ("Determination of Electricity Supplied and Taken Under RS 1821/1880"), 14 September 2001 at 31, R-188.

incentive agreement) was the basis for setting the GBL for the 2009 EPA.⁴⁷ Without the incentive and obligations of an EPA, Tembec represented, and BC Hydro agreed, that

[REDACTED]

36. I agree with Mr. Switlishoff when he states: [REDACTED]

[REDACTED]

[REDACTED]⁴⁸ He cites to paragraph 102 of my first witness statement but misunderstands what I said there. Paragraph 102 was intended only as a general introduction to that section of my witness statement. Mr. Switlishoff should have understood from paragraphs 105 to 111 of my first witness statement that neither BC Hydro nor Tembec [REDACTED]

[REDACTED] However, paragraph 102 could be clarified as follows:

102. If Tembec terminated the 1997 EPA and stopped producing power as a result of high fuel costs, [REDACTED]

[REDACTED]

37. The Claimant states in its Reply that the energy flow diagrams BC Hydro submitted to the BCUC in its Justification Report for the Skookumchuck 2009 EPA,⁴⁹ and which I discussed in my first witness statement⁵⁰ “were not hypothetical scenarios; they were supposed to illustrate power flows before and after the two EPAs so as to justify the GBL.”⁵¹ They continue, saying that:

⁴⁷ Lester Dyck Statement II, ¶¶ 106-109.

⁴⁸ Switlishoff Expert Statement II, ¶¶ 72-3.

⁴⁹ See Justification Report, Tembec EPA Replacement for Incremental Energy Sales from Purcell Power Plant, Attachment 1 at bates152604, R-192.

⁵⁰ Lester Dyck Statement I, ¶ 116.

⁵¹ Claimant’s Reply, ¶ 459.

BC Hydro presented them in a misleading way such that it failed to disclose that the 2009 EPA permitted Tembec to sell more power to BC Hydro only because it afforded Tembec greater access to BC Hydro power to arbitrage. ...⁵² What was the point of using [REDACTED] instead of recent [REDACTED] (at least for the 1997 post-COD scenarios) and post-2009 expected energy purchases, if not to disguise that Tembec would be allowed to [REDACTED] its purchases of BC Hydro embedded cost power?

38. The Claimant continues to misunderstand the Justification Report. As I explained in my first witness statement, [REDACTED]

[REDACTED]
[REDACTED]⁵³

39. As I also explained in my first witness statement, when the EPA approach is used to incentivize incremental self-generation, incremental below-load electricity is deemed to be delivered to BC Hydro and the customer is deemed to purchase the amount of electricity that they would have purchased in the absence of the deemed delivery. The purchases and sales do not reflect the actual physical energy flows.⁵⁴ The Claimant draws erroneous conclusions about Tembec's energy purchases by erroneously assuming that [REDACTED]

40. The Claimant also errs by comparing Tembec's purchases when operating under the 2009 EPA to its purchases when operating under the 1997 EPA. The relevant comparison is the amount of electricity Tembec buys and sells while operating under the 2009 EPA as compared to what it would buy and sell while operating under no EPA (*i.e.* in the absence of any incentive agreement which would be the case when the 1997 EPA terminated).

⁵² Claimant's Reply, ¶ 459.

⁵³ Lester Dyck Statement I, ¶ 116. Energy Diagrams from Justification Report, Tembec EPA Replacement for Incremental Energy Sales from Purcell Power Plant, Attachment 1 at bates152604, **R-192**.

⁵⁴ Lester Dyck Statement I, ¶¶ 29-30.

Figure 1: Tembec Energy Flows⁵⁵

After 2009 EPA

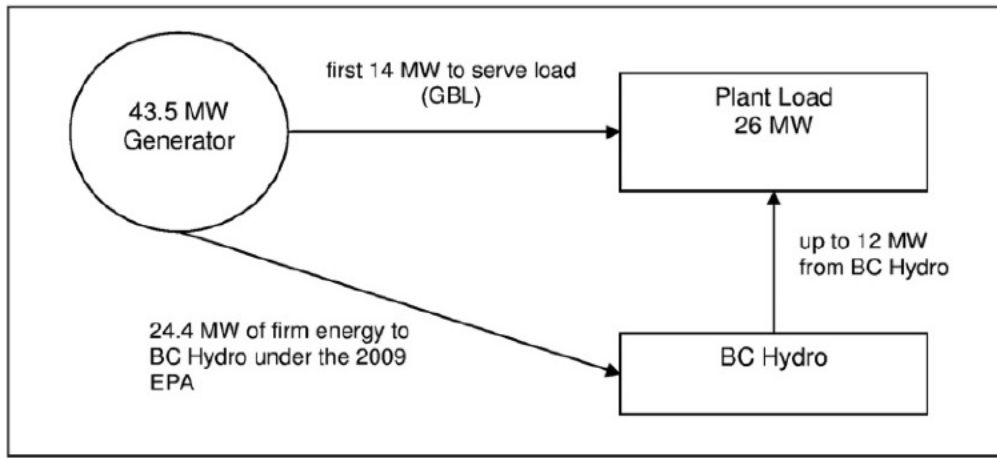

41. As I explained in my first witness statement, and referencing Figure 1 above,

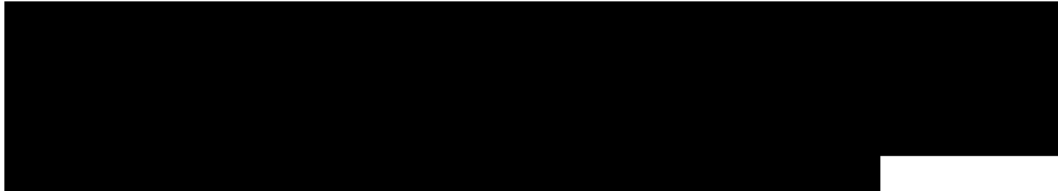

42. Accordingly when the level of Tembec’s electricity purchases when operating under the 2009 EPA are appropriately compared how much they would purchase in the absence of an EPA, there is no increase in Tembec’s electricity purchases. Mercer’s allegation arises from failing to recognize this fundamental point.

2. Clarifications on the Model

43. Mr. Switlishoff offers many critiques about the [REDACTED] used in the determination of the GBL for the Skookumchuck 2009 EPA.⁵⁷ For example, he states that he was “unable to find any independent analysis by ... BC Hydro that

⁵⁵ See Justification Report, Tembec EPA Replacement for Incremental Energy Sales from Purcell Power Plant, Attachment 1 at bates152604, R-192.

⁵⁶ Lester Dyck Statement I, ¶¶ 116.

⁵⁷ See, for example, Switlishoff Expert Statement II, ¶¶ 65-7;70-1.

corroborated the results of Tembec's model."⁵⁸ BC Hydro did run its own [REDACTED] analysis. Early on in the negotiations, I asked one of our engineers, Norman Wild, to provide input into the determination of Tembec's GBL. Using an equivalent software to that used by Mr. Lague of Tembec, Mr. Wild ran [REDACTED] analysis to check the one conducted by Mr. Lague. I recall that Mr. Wild's [REDACTED] analysis confirmed Tembec's [REDACTED] analysis was reasonable with respect to [REDACTED]. However, Mr. Wild advised me that his [REDACTED] analyses for the Skookumchuck mill was lost in a file migration and accordingly it is not on the record of this proceeding. This would explain why Mr. Switlishoff was unable to find it.

44. At paragraphs 70-71 of his second statement, Mr. Switlishoff lays out the following additional critique (footnotes omitted):

70. Tembec's engineer responsible for the steam and generation model, Mr. Lague, describes that the model analysis results as presented in Pöyry-54 employed the following assumption: "A fundamental principle in the GBL calculations at Skookumchuck is that, [REDACTED]"

71. This reference conflates two issues that should properly be kept separate: the distinction between the operations that would have existed but for the 2001 Skookumchuck EPA, and the infrastructure that was incentivized by the 2001 Skookumchuck EPA. [REDACTED]

[REDACTED] and as a result, any GBL determination based on the results of this model analysis are inconsistent the "current normal" methodology.

45. Mr. Switlishoff confuses several things in this passage. First, he misunderstands the [REDACTED] models that were generated by Tembec, and separately run by BC Hydro as noted above. These [REDACTED] models were focused on [REDACTED]

⁵⁸ Switlishoff Expert Statement II, ¶ 67.

[REDACTED]
[REDACTED]
[REDACTED] As the mill had [REDACTED]
[REDACTED]
[REDACTED] BC Hydro and Tembec determined
[REDACTED]
[REDACTED]
[REDACTED]

46. Second, Mr. Switlishoff cites to the initial position taken by Tembec in the negotiation, and assumes that this was the end result of the GBL negotiation. That assumption is not correct. Tembec's proposal was not accepted at face value. In fact, BC Hydro adopted the same critique of Tembec's position as Mr. Switlishoff articulates in the passage cited above: [REDACTED]
[REDACTED]

As discussed above, the GBL determination correctly assumed that Skookumchuck
[REDACTED]
[REDACTED]

47. I agree with Mr. Switlishoff that the appropriate GBL for the Tembec 2009 EPA needs to be based on the equipment that was installed and operating at Skookumchuck under normal operating conditions at the time of EPA negotiation. [REDACTED]
[REDACTED]
[REDACTED] the GBL of 14 MW was set.⁵⁹

48. Similarly, I could not and did not accept Mr. Merwin's proposal that we ignore Celgar's Project Blue Goose efficiency improvement projects, completed in 2006, when determining Celgar's GBL for its 2009 EPA. [REDACTED] the appropriate GBL for the Celgar 2009 EPA was based on the equipment that was installed

⁵⁹ See also Lester Dyck Statement I, ¶¶ 107-110.

and operating at the Celgar mill under normal operating conditions at the time of EPA negotiation.

D. THE GBL IN HOWE SOUND'S 2010 EPA

49. Like for Celgar and the others, BC Hydro considered historical generation data at the Howe Sound mill to determine the GBL for the Howe Sound 2010 EPA. Unlike with Celgar, [REDACTED]

[REDACTED]⁶⁰ First, we did not believe [REDACTED]

[REDACTED]⁶¹ Second, as described in my first witness statement,⁶² and in the witness statement of Fred Fominoff,⁶³ Howe Sound [REDACTED]

[REDACTED] Finally, Howe Sound's [REDACTED]⁶⁴

50. Mr. Switlishoff suggests that [REDACTED]⁶⁵ [REDACTED]
[REDACTED]
[REDACTED]
[REDACTED]
[REDACTED]
[REDACTED]
[REDACTED]
[REDACTED]
[REDACTED]

⁶⁰ Lester Dyck Statement I, ¶ 127.

⁶¹ Lester Dyck Statement I, ¶ 128.

⁶² Lester Dyck Statement I, ¶ 124.

⁶³ Fred Fominoff Statement, ¶¶ 15-20.

⁶⁴ Lester Dyck Statement I, fn 136. [REDACTED]

⁶⁵ Switlishoff Expert Statement II, ¶¶ 85-86.

51. [REDACTED]⁶⁶ [REDACTED]
[REDACTED]⁶⁷ [REDACTED]
[REDACTED] As discussed with Scott Janzen, the Key
Accounts Manager for Howe Sound, and confirmed in an email, the [REDACTED]
[REDACTED]
[REDACTED]⁶⁸ Mr. Janzen went on to clarify [REDACTED]
[REDACTED]
[REDACTED]
[REDACTED]
[REDACTED]
[REDACTED]⁶⁹ I
note that Mr. Fominoff describes the GBL set period in the same manner in his witness
statement:

Howe Sound and BC Hydro agreed that the generation data [REDACTED]
[REDACTED]
[REDACTED]

52. In his second statement, Mr. Switlishoff observes that, for Celgar, [REDACTED]
[REDACTED]
[REDACTED]⁷¹ [REDACTED]
[REDACTED]
[REDACTED]⁷² The answer is simple: the mills' generation realities were
different. In the case of Howe Sound, [REDACTED]

⁶⁶ Lester Dyck Statement I, fn138.

⁶⁷ See, for example, Lester Dyck Statement I, ¶¶ 129, 130, 132.

⁶⁸ Email from Scott Janzen to Lester Dyck, Re: HSPP GBL, 3 November 2010, R-67.

⁶⁹ Email from Scott Janzen to Lester Dyck, Re: HSPP GBL, 3 November 2010, R-67.

⁷⁰ Fred Fominoff Statement, ¶ 33.

⁷¹ Switlishoff Expert Statement II, ¶ 85.

⁷² Switlishoff Expert Statement II, ¶ 85.

[REDACTED]
[REDACTED]
[REDACTED] In the case of Celgar, [REDACTED] 2007 represented normal operations for the mill going forward. The mill's efficiency and other improvement projects, such as Project Blue Goose, had been substantially completed in 2006. In addition to the written communications Celgar submitted into the RFP process,⁷³ Mr. Merwin expressed this reality to me in conversations about the mill's operations. Using a [REDACTED] approach would have simply determined the wrong GBL for Celgar's 2009 EPA.

E. HOWE SOUND'S 2001 CONSENT AGREEMENT

53. In his second report, Mr. Switlishoff claims that "it does not appear possible that actual generation data could have supported a GBL determination [for Howe Sound in 2001] of [REDACTED] MW."⁷⁴ I was not involved when the original arrangements between Howe Sound, Powerex and BC Hydro, including the Consent Agreement, were agreed to in 2001.⁷⁵ However, further to the explanation I provided in my first witness statement on the basis of documents, and my conversations with Howe Sound's then-Key Accounts Manager,⁷⁶ a letter Pierre Lamarche from Howe Sound wrote to me concerning the [REDACTED]

[REDACTED]⁷⁷ In his letter, Mr. Lamarche stated that:

⁷³ Letter from Brian Merwin to BC Hydro RFP Administrator, re: Zellstoff Celgar Limited Partnership ("Celgar") - Biomass Realization Project and Celgar Green Energy Project, dated May 7, 2008, p. 7, **R-127** (showing "Celgar Operation 2007" diagram that "represents how Celgar typically operates after Mercer capital investments." This diagram shows a 2007 "March" mill load of 43 MW, generation levels for the same of 48 MW, and exports of 5 MW.)

⁷⁴ Switlishoff Expert Statement II, ¶ 47.

⁷⁵ See Purchase Transaction Enabling Agreement between Powerex Corp and Howe Sound General Partner Ltd., 12 April 2001, **R-84**; Consent and Electricity Purchase and Sale Agreement between Howe Sound, Powerex and BC Hydro, 12 April 2001, **R-85**.

⁷⁶ Lester Dyck Statement I, ¶¶ 39-40.

⁷⁷ Letter from Pierre Lamarche to Lester Dyck, 17 March 2004, **R-396**.

[REDACTED]

54. The Claimant also asserts that “BC Hydro continued Howe Sound’s GBL in subsequent [REDACTED] without ever examining whether that generation would cease to exist (*i.e.* be idled because it remained uneconomic) without the incentive of the Powerex Agreement.”⁷⁹ I was personally involved in the discussions surrounding the [REDACTED] of the mill’s 2001 Consent Agreement [REDACTED]. Each time, I consulted with BC Hydro’s internal counsel and others within BC Hydro, and had conversations with mill personnel about any changes in operations that may have occurred in the previous year. In these years, I dealt with Mr. Lamarche at Howe Sound.

55. Mr. Lamarche’s letter, referenced above, also illustrates the type of conversation held between BC Hydro and Howe Sound regarding [REDACTED] the agreement. He stated in his letter that: [REDACTED]

[REDACTED]

[REDACTED]

[REDACTED]

[REDACTED]

⁸⁰

56. As stated in Mr. Lamarche’s letter, one of the reasons Howe Sound’s [REDACTED] [REDACTED] At all times that I was involved, natural gas prices did not drop significantly [REDACTED]

⁷⁸ Letter from Pierre Lamarche to Lester Dyck, 17 March 2004 at 134935, R-396.

⁷⁹ Claimant’s Reply, fn 383. See also Claimant’s Reply, ¶¶ 340-346; Switliff Expert Statement II, ¶ 48.

⁸⁰ Letter from Pierre Lamarche to Lester Dyck, 17 March 2004 at 134936, R-396.

Thus, the conditions underlying the [REDACTED] threshold had remained the same, and we saw no reason to alter it.

57. Before I became personally involved in the discussions surrounding the [REDACTED] mill's 2001 Consent Agreement [REDACTED] Craig Folkestad was the Key Accounts Manager responsible for Howe Sound. Based on conversations I have had with Mr. Folkestad I understand that, [REDACTED] a process very similar to the one I described for [REDACTED] was undertaken and for the same reasons the [REDACTED] MW threshold was not altered.

* * *

58. I affirm that the information provided above is true and correct.

59. I affirm this witness statement in support of Canada's Rejoinder Memorial in the *Mercer International Inc. v. Government of Canada* NAFTA arbitration and for no improper purpose.

AFFIRMED BEFORE ME)
at the City of Vancouver)
in the Province of British Columbia,)
this 9th day of April, 2015.)
_____)
A Commissioner for taking Affidavits for)
British Columbia.)

_____)
LESTER DYCK

VICKI B. ANTONIADES
Barrister & Solicitor
17th FLOOR-333 DUNSMUIR STREET
VANCOUVER, B.C.
V6B 5R3